

**P.A. – S.p.A. – EQUIPAGGIAMENTI TECNICI DEL LAVAGGIO**

VIA MILANO, 13 – CASELLA POSTALE 115 – 42048 RUBIERA (REGGIO EMILIA) – ITALY  
 Tel. +39 0522 623611 – Fax. +39 0522 629600 – R.E.A. RE 156319 – R.I. RE11535 – Mecc. RE 013446  
 C.F. e P. IVA 01035950359 – Cap. Soc. i.v. € 750.000,00 – Codice Identificativo C.E.E. IT 01035950359  
 ART. 2497 – BIS C.C. DIREZIONE E COORDINAMENTO BENETTI srl R.I. TRIB. DI RE 01480690351  
 Web: <http://www.pa-etl.it> – E-mail: [info@pa-etl.it](mailto:info@pa-etl.it)



## RF1 – Flow regulator

**DN6**

- Flow regulator with internal variable geometry restriction, adjusted via control knob.
- Allows continuous and precise flow adjustment without acting on the valve or the pump.
- Ideal for applications requiring fine pressure and flow regulation.
- Made of brass with reinforced plastic knob, suitable for use with hot water.

### TECHNICAL SPECIFICATIONS

Materials		Brass, with plastic knob.								
Maximum Temperature (1)		160 °C - 320 °F								
P/N	Rated Pressure		Permissible Pressure		Max. Flow Rate		Weight		Inlet	Outlet
	bar	MPa	bar	MPa	l/min	USGp m	g	oz.		
29.0400.10	250	25	280	28	30	8	186	6.6	G 1/4" M	G 1/4" F

(1) The accessory is designed for continuous use with water at 90°C (195°F). It can withstand a maximum temperature of 160°C (320°F) only for short periods. This is because, when the gun is closed, the boiler continues to transfer heat to the water, increasing its temperature and pressure to potentially dangerous levels.

When using the lance with water temperatures above 60°C, the operator must use appropriate personal protective equipment (e.g., gloves).

**Instruction manual, maintenance, installation, spare parts.**  
 For a correct utilization, follow the directions of this manual  
**Re-print them on the Use and Maintenance booklet of the machine.**

n. MPA.0038.EN

## OVERALL DIMENSIONS

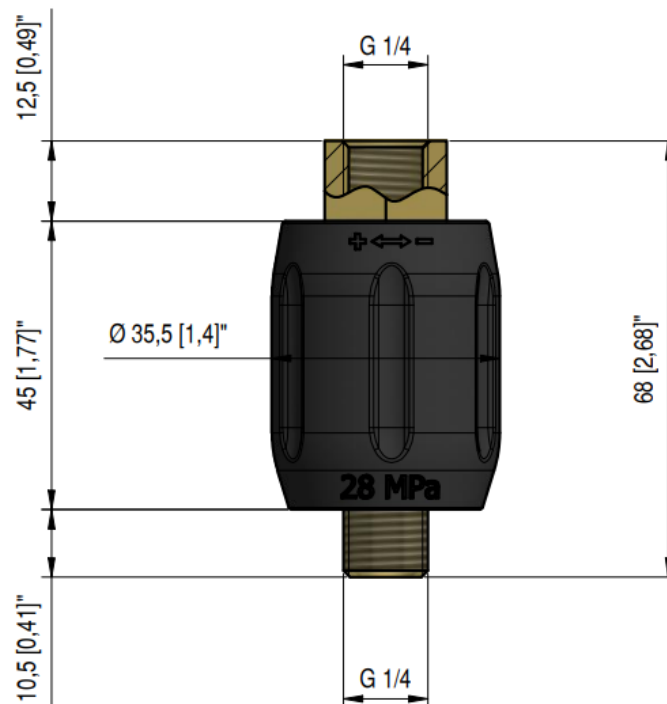

## INSTRUCTIONS

This product is suitable for use with clean, fresh water, possibly with mild additives or standard detergents. For use with other fluids, especially if they are corrosive, please consult our technical department.

Adequate filtration must be used. Select the lance based on the nominal operating conditions (nominal pressure, maximum flow rate, and system temperature). Under no circumstances should the machine's overpressure exceed the maximum allowable pressure marked on the lance.

## INSTALLATION

It is recommended to install the RF1 flow regulator between the gun and the lance, and to mount a nozzle at the end of the lance that is properly sized according to the system specifications. To assess suitability in applications other than those indicated, contact our technical department.

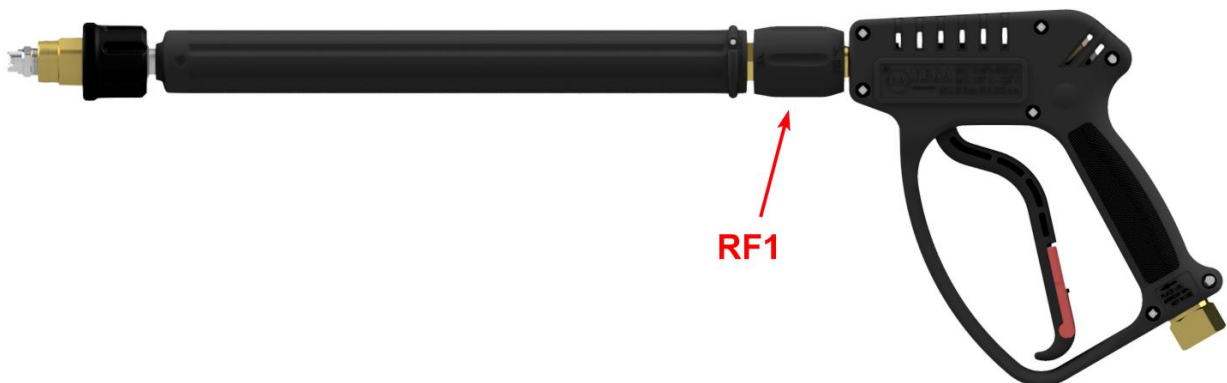

Clean all threads and sealing surfaces thoroughly before installation. Avoid overtightening, which may damage the seals or deform components. Use suitable sealants to prevent leaks in threaded connections. Check for proper sealing before pressurizing the system.

This accessory was designed to operate also with **hot water** (in compliance with the technical specs). Equip the **hot water** generator with a device that limits any accidental temperature increase of the fluid.

**Always** install an appropriately calibrated relief or safety valve on the high-pressure line of the system.

Adjust the valve installed upstream of the gun to ensure a constant supply and avoid sudden pressure spikes when closing the system. If the nozzle wears out, the pressure drops. After installing a new nozzle, adjust the system back to the original pressure.

## OPERATIONS

By turning the RF1 knob according to the arrows molded into the plastic, the internal components are actuated, adjusting the flow passage area.

This results in the following extreme conditions:

- Knob fully open: the flow rate is approximately the same as if the RF1 were not installed.
- Knob fully closed: maximum restriction and minimum flow rate.

Between these two positions, the flow rate can be adjusted continuously and precisely. Pressure will decrease in proportion to the flow rate.

The following chart shows how flow rate and pressure vary with three different nozzles as the RF1 setting is changed. Pressure was measured downstream of the RF1 and upstream of the nozzles.

Note: The graph is for reference only. Actual flow and pressure values may vary depending on the specific system configuration.

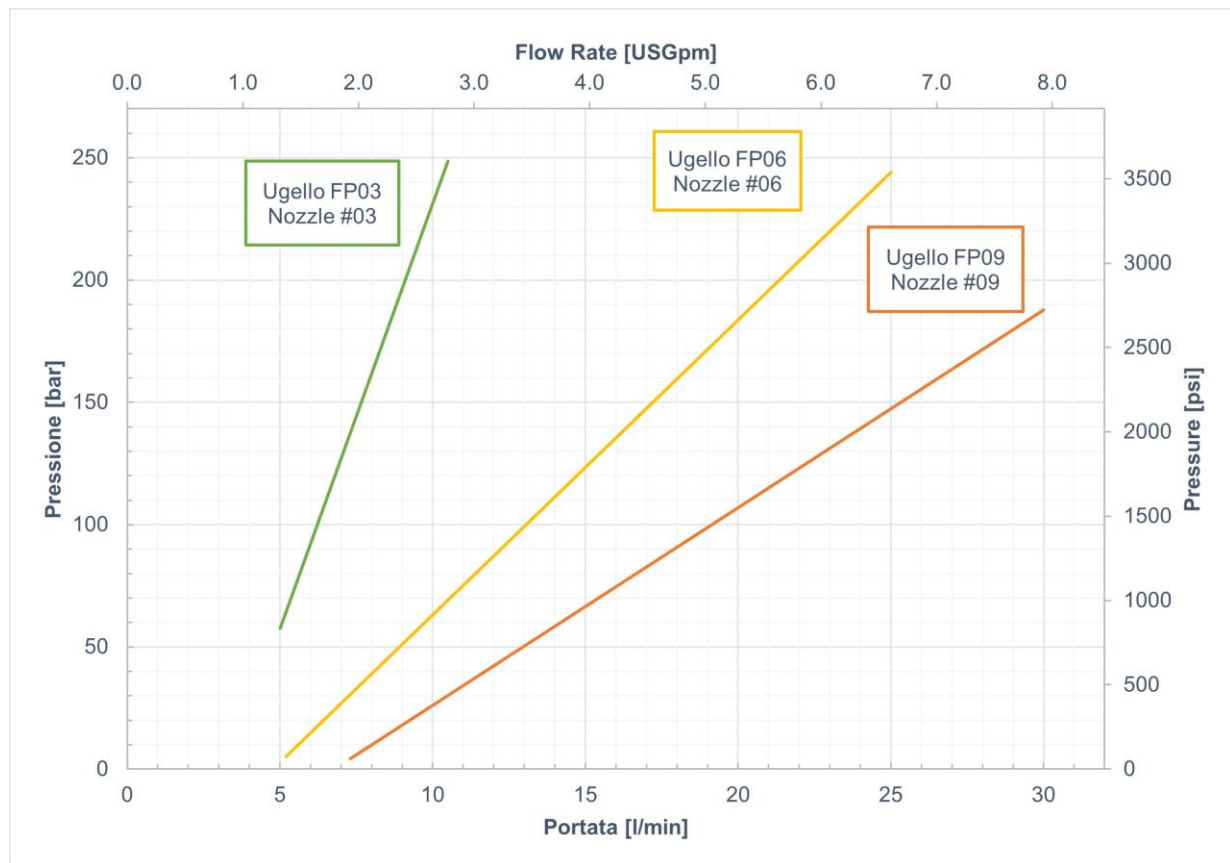

**WARNING:** As RF1 is progressively closed, flow rate and downstream pressure decrease, while upstream pressure increases. The extent of this pressure increase depends on the specific application.

This behavior should be considered when designing the system and, if necessary, verified through preliminary testing.

The following graph shows an example case, illustrating the upstream pressure increase:

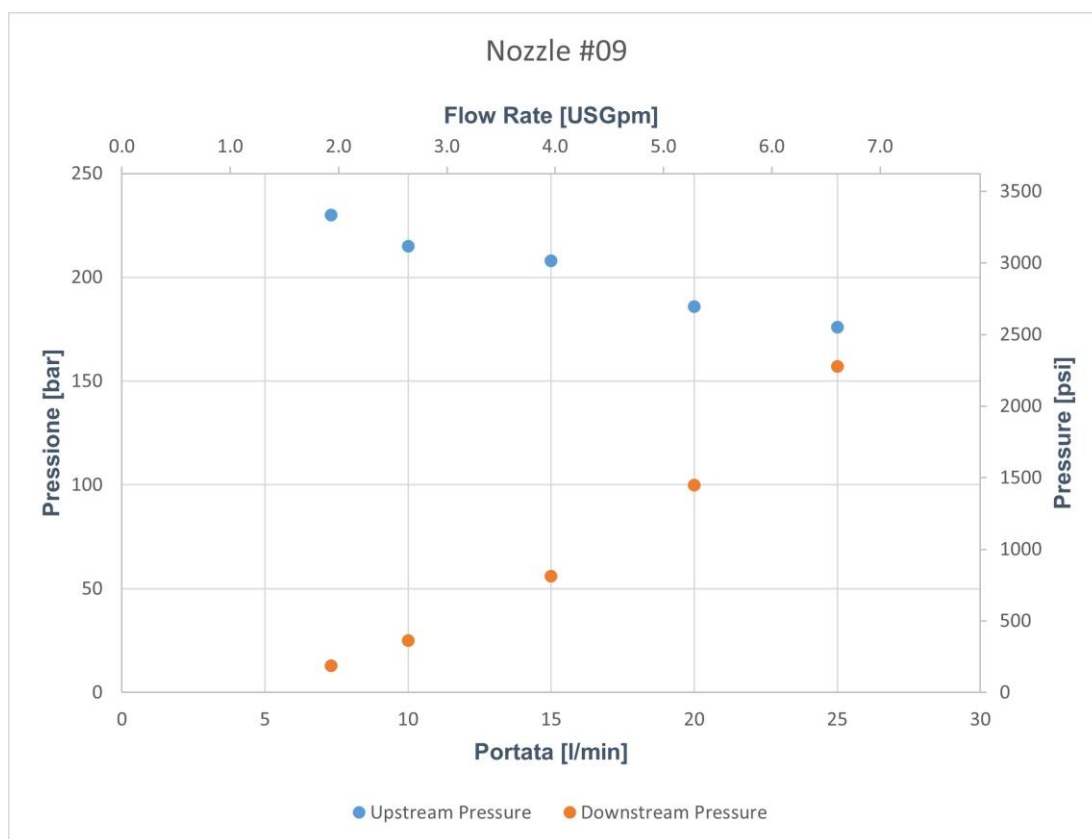

## WATER SUPPLY LINE

In cases of high or highly variable supply pressures, it is necessary to install a pressure reducer. This helps stabilize the inlet flow and protect the system components.

## PROBLEMS AND SOLUTIONS

PROBLEMS	PROBABLE CAUSES	SOLUTIONS
Leakages from the seals	Seals worn out	Replace the seals

## SAFETY WARNINGS

- Never exceed the permissible pressure.
- Do not modify the accessory or remove safety components.
- Always wear suitable PPE (gloves, safety goggles, non-slip footwear).
- Do not use with incompatible or corrosive fluids without prior technical approval.
- Perform periodic checks to prevent malfunctions.
- Never leave the accessory unattended while the system is pressurized.
- Use only original spare parts to ensure compatibility and performance.

## REGULATIONS

The design and construction of our products comply with norm CEI EN 60335-2-79 first edition, published in 1999-03 and its respective variations on the project norm prEN 1829.

Read this manual before starting the assembly.

For a correct utilization, follow the directions described in this manual and re-print them on the Use and maintenance manual of the machine.

The present manual is valid for all the accessories named **RF1**.

## MAINTENANCE

**Note:** All maintenance operations - both ordinary and extraordinary - must be carried out exclusively by qualified and specialized personnel to ensure safety and proper product operation. Maintenance is essential to ensure correct functioning and to extend the lifespan of the accessory.

### Ordinary Maintenance (every 400 operating hours):

- Periodically check the condition of seals and wear components.
- Clean filters to avoid impurity buildup.
- Check for any leaks in fittings and connections.
- Lubricate moving parts.

### Extraordinary Maintenance (every 800 operating hours):

- Replace seals and deteriorated components.
- Disassemble and thoroughly clean the accessory to remove scale or buildup.
- Check the structural integrity of components and replace any damaged parts.
- Perform a functionality test before putting the accessory back into service.

**DISCLAIMER:** The manufacturer is not liable for any damage resulting from:

- Incorrect installation or failure to follow the provided instructions.
- Use of non-original spare parts.
- Maintenance performed by unqualified personnel.
- Unauthorized modifications to the product.

*This manual is subject to updates and modifications without notice, to ensure the information remains accurate and aligned with product improvements. It is recommended to periodically check for the latest version available.*

## 29.0400.10 RF1 Flow regulator 1/4MF Bsp

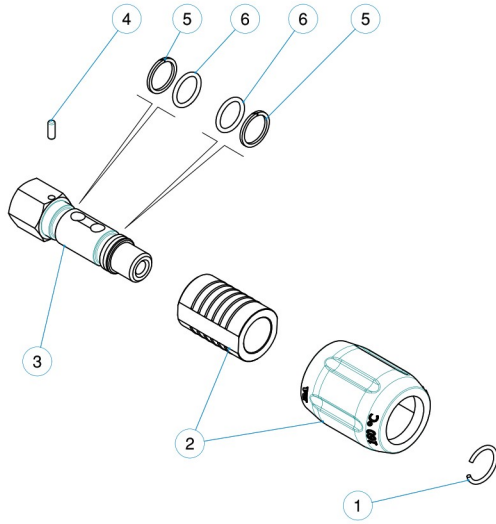

Pos.	P/N	Description	Q.ty	K1	K2	K3	K4	
1	29.0402.51R	Snap ring, 1,6x14,3 mm Sst.	1					5
2	29.0408.22R	Knob -RF1, v.2 -PA black	1					3
3	29.0406.31R	Hollow shaft, 1/4Bsp MF brass	1					3
4	15.1018.00R	Parallel pin, 3x8 mm Sst.	1					10
5	10.4013.00R	Back-up ring, 16x13,2x1,2 mm	2					10
6	10.3060.00R	O-ring, 1,78x12,42 mm	2					10